



33.6W Power Over Ethernet Adapter High Power single port injector.



Features

- Fully Compliant detection, disconnect and voltage control IEEE802.3af
- Diagnostic LEDs
- Non-Vented Case
- Classification per 802.3at
- UNH IOL Tested
- Full Protection OCP, OVP
- Gigabit Compatible

Applications

- IP Telephones
- Wireless Network Access Points
- Blue Tooth Access Point
- Security Camera
- IP Print Servers

Safety Approvals

- cUL/UL
- CE
- S-Mark
- CCC
- C-Tick
- SAA
- KTL
- RoHS

Mechanical Characteristics

- Length: 140mm (5.51in)
- Width: 65mm (2.55in)
- Height: 36mm (1.42in)
- Weight: 0.2Kg (0.44lb.)

Output Specifications

Model	DC Output Voltage	Load		Regulation	
		Min.	Max.	Line	Load
POE36U-1AT	56V	0A	0.60A	54-57Vdc under all conditions	

Ripple And Noise*	Vp-p*
<500Hz	0.5
500Hz-150KHz	0.15
150KHz-500KHz	0.15
500KHz-1MHz	0.1

*As per IEEE802.3af Table 33-5.

Phihong is not responsible for any error and change. Content is subject to change without notice. Please consult the factory and visit www.phihong.com for the most up-to-date specifications.

INPUT:

AC Input Voltage Range

90 to 264VAC

AC Input Voltage Rating

100 to 240VAC,47-63Hz

AC Input Current

1.0A(RMS) max. for 90VAC

0.55A(RMS) max. for 240VAC

Leakage Current

3.5mA max. @ 254VAC 60Hz

AC Inrush Current

30A(RMS) max. for 115VAC

40A(RMS) max. for 230VAC

OUTPUT:

Total Output Power

33.6W

DC Offset

No Data degradatio with DC imbalance 18mA

Efficiency

78% (typical) at Max. load, and 120VAC 60Hz

Hold-up Time

16mS min. 120VAC and max. load

Transient O/P Voltage Protection

60V max.

ENVIRONMENTAL:

Temperature

Operation -20 to +50°C

Non-operation -25 to +65°C

Humidity

Operation 5 to 90%

EMC

FCC Part 15 Class B

EN55022 Class B

Isolation Test

Primary to Secondary: 3000VAC for 1 minute 10mA

Primary to F.G.: 1500VAC for 1 minute

Output to F.G.: 1500VAC

Immunity

ESD: EN61000-4-2. Level 3

RS: EN61000-4-3. Level 2

EFT: EN61000-4-4. Level 2

Surge: EN61000-4-5. Level 3

CS: EN61000-4-6. Level 2

Voltage Dips EN61000-4-11

Harmonic: EN61000-3-2

Insulation Resistance

Primary to secondary: >10M OHM 500VDC

Primary to FC: >10M OHM 500VDC

FEATURE:

Over Voltage/Current, Short Circuit Protection

Outputs equipped with short circuit protection and overload protection as per 802.3at specification

The output can be shorted permanently without damage

Indicators

Led #1 indicator for input power “on” GREEN

Led #2 Indicator for Class 4 PD connected GREEN

Led #3 Indicator that Detected and Connected to valid

IEEE802.3af load-GREEN

Input Connector

IEC320 inlet 3 pin

Output Connection

+pins 3,6

- pins 1,2

Dimension Diagram Unit: mm (inch)

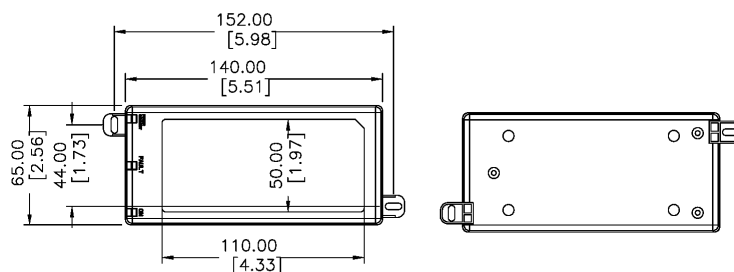

Gigabit Power Injector Block Diagram

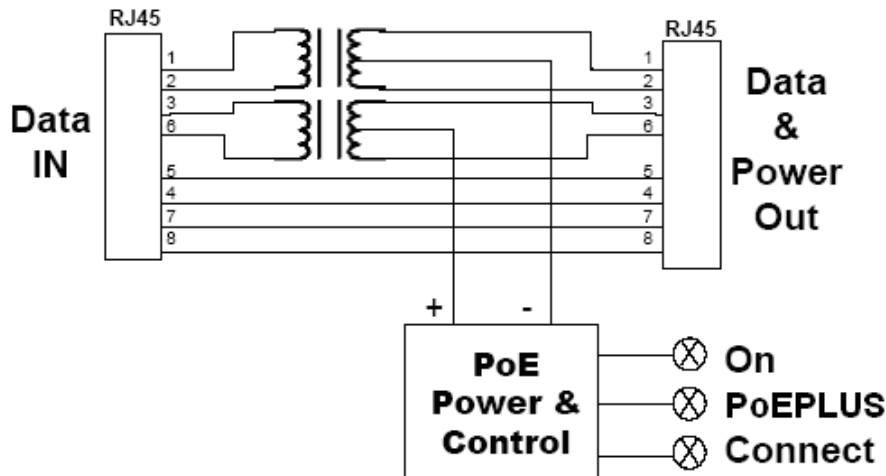

Description of LED Functions for Gigabit Power Injector

Power-up Sequence:

Upon power-up, all 3 LEDs will light for 2 seconds, as part of the self-test for the internal microprocessor software. After the end of the 2 seconds, the "ON" LED will illuminate green, signifying that the DC output voltage is available for powering a compliant load (to the 802.3af PoE standards).

Detection Sequence:

Once a compliant load is attached to the output RJ45 connector, the green "CONNECT" LED will illuminate. Should the load is classified as Class 4 PD, the green "PoEPLUS" LED will illuminate. Otherwise, "PoEPLUS" LED will stay off.

Should the load be non-compliant then the LEDs will blink a code signifying the cause for non-detection.

Detection Failure Codes:

1. Incorrect resistive signature – The green "CONNECT" and green "PoEPLUS" LEDs will blink 3 times.
2. Incorrect capacitive signature – The green "ON" LED will blink 3 times.
3. Incorrect Voffset – The green "CONNECT" and green "ON" LEDs will blink 3 times.
4. Unstable current measurement – The green "CONNECT" LED will blink 3 times
5. Low voltage sensed during detection (overload) – The green "PoE PLUS" LED will blink 3 times

After the LEDs blink 3 times the PSE will continue to try to detect a valid load. Therefore, until the correct load is applied, the LEDs will continue to blink. If there is an open circuit connected to the output RJ45 then the LEDs will not blink but the PSE will continue to try to detect a valid load.

Fault Sequence:

Should there be a fault such as an overload or short circuit then all the three LEDs will blink 5 times in 2 seconds, and then go off as the power supply tries to re-detect a valid load. If there is a problem in detecting, the LED will indicate what is wrong with the load as per the codes in the section above.